

NEXT HIGHER ASSY:

ASSOCIATED FILES:

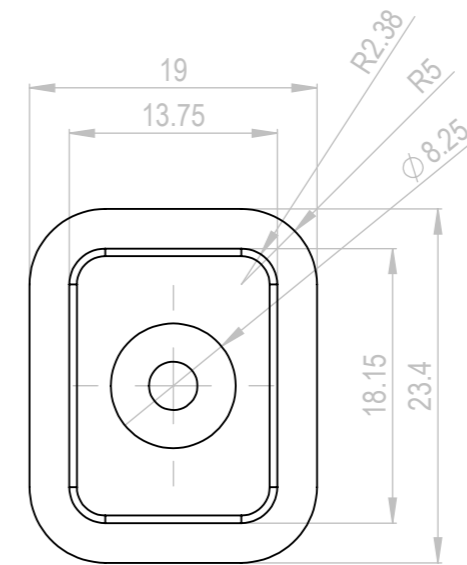
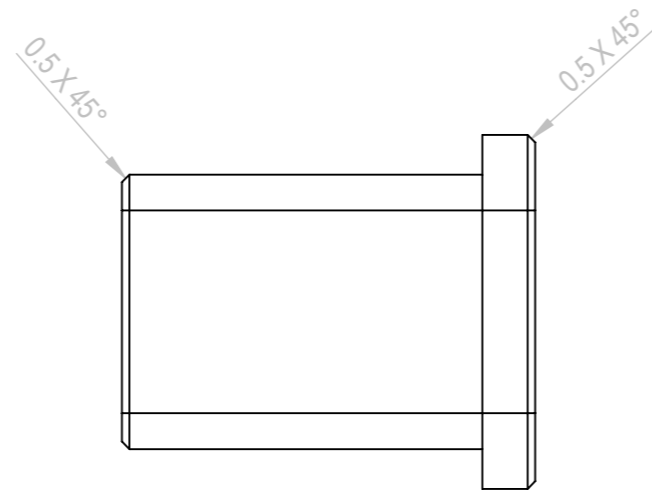
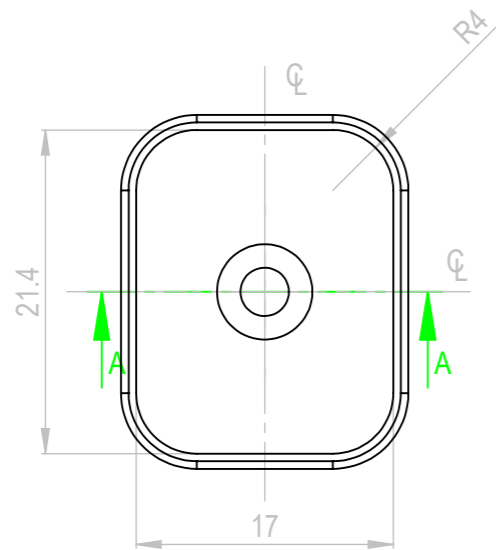
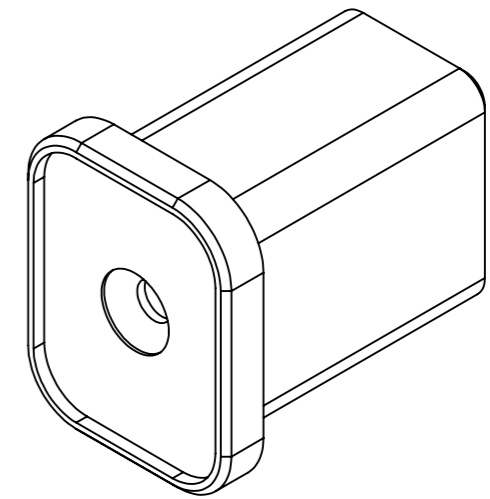
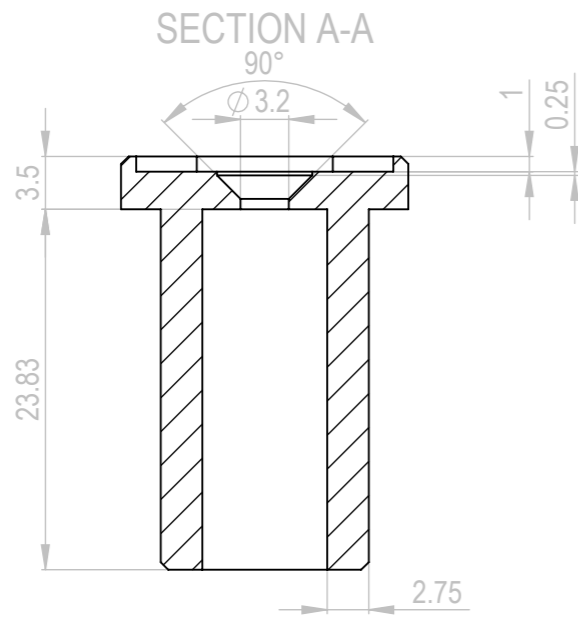

NOTES:

1. MATERIAL: ACETAL(BLACK),
2. MATERIAL CERTIFICATION REQUIRED
3. FINISH: SATIN FINISH SAND BLAST,
4. BREAK (0.1~0.2) SHARP EDGES & RADIUS
5. REMOVE ALL BURRS
6. FIRST ARTICAL INSPECTION REPORT ON ALL DIMENSIONS
7. GENERAL OVER CHAMFER 0.25mmX0.25mm
8. QTY PER UNIT: 2

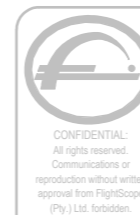

MATERIAL:

TEXTURE:  
FINISH:  
WEIGHT(g):

TOLERANCE

UNLESS OTHERWISE SPECIFIED  
DIMENSIONS ARE IN MILLIMETERS  
LINEAR

0 = ±0.5  
0.0 = ±0.25  
0.00 = ±0.15  
0.000 = ±0.015

SURFACE =  
S/METAL BEND <math>\leq \pm 0.2^\circ</math>  
MACHINED ANGLE <math>\leq \pm 0.2^\circ</math>

DESCRIPTION

E47-V0003-A

PRT. NO

FS Xi FOOT

FIRST ANGLE  
PROJ.



DO NOT SCALE DRAWING

SCALE

2:1

SHEET

1 OF 1

PAPER SIZE

A3

OFFICIAL RELEASE

13/09/2013

HB

TJ

HB

DETAIL

DATE

DRW

CH'CK'D

ENG